

# BALLOSTAR® KHA-G

## Threaded connection

### GENERAL FEATURES

- » 3-piece ball valve with full or reduced bore
- » Floating ball, antistatic, lockable
- » Double tightness in both directions
- » Modular system components

### CONNECTIONS

Internal thread Rp in accordance with EN 10226-1

### DIMENSIONS

Face-to-face dimensions in accordance with DIN 3202 Pt. 4

### ACCEPTANCE TESTING

- » Seat leak tightness: EN 12266-1 P12, leakage rate A
- » Tightness to atmosphere: EN 12266-1 P11
- » Strength: EN 12266-1 P10

### AUTOMATION

Flange connection in accordance with ISO 5211, allows for direct mounting of an actuator or by means of brackets. Pneumatic and electrical actuators utilizable.

### TEMPERATURE

-196 °C to +400 °C (see pT diagram)

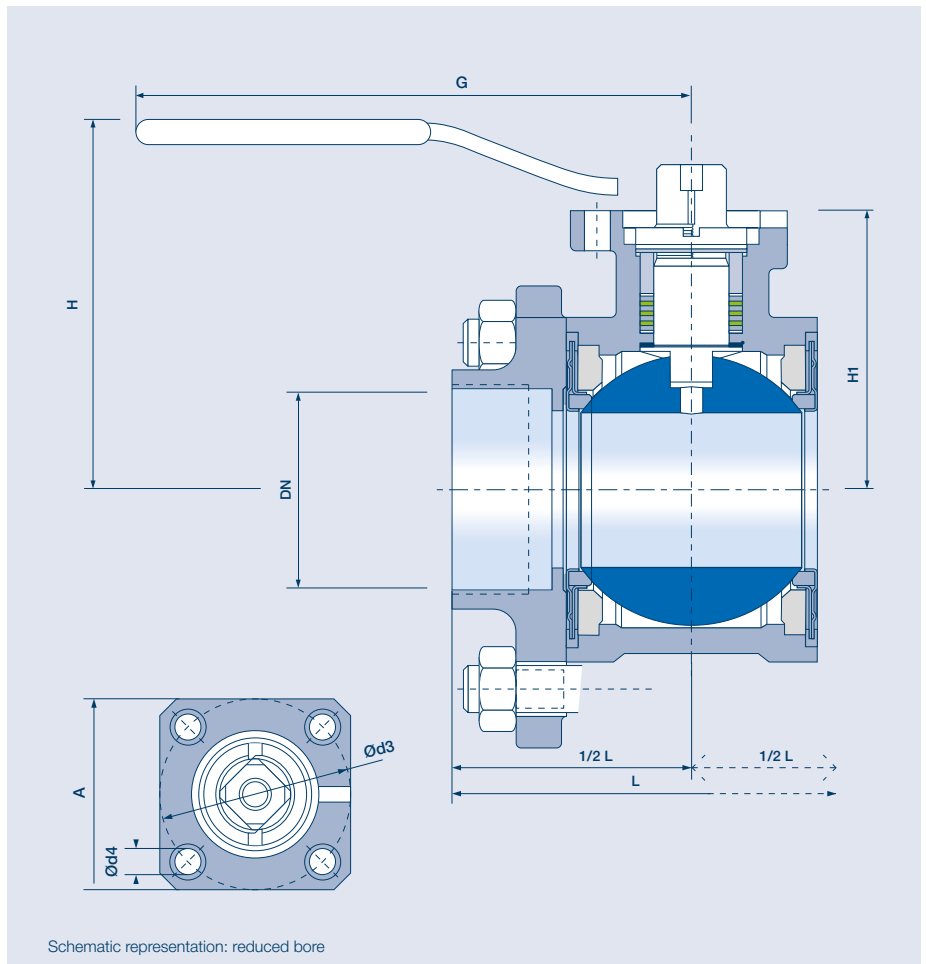

## KHA-G VARIANTS

### FULL BORE

Material: Grey cast iron EN-GJS-400-15 (Material code III)\*  
Steel casting 1.0619 (Material code VIII)  
Stainless steel casting 1.4408 (Material code Xc)

\*refers to threaded connection, body made of cast steel

### REDUCED BORE

Material: Steel casting 1.0619 (Material code VIII)  
Stainless steel casting 1.4408 (Material code Xc)

DN	Dimensions				PN			Mounting flange for actuator				Weight kg
	L	H	H1	G	III	VIII	Xc	ISO	A	Ød3	Ød4	
3/8"	75	80	35	130		100	63	F04	42	42	5.8	0.8
1/2"	85	80	35	130		100	63	F04	42	42	5.8	0.9
3/4"	95	94	46	160		100	63	F04	42	42	5.8	1.5
1"	105	98	50	160		63	40	F04	42	42	5.8	1.9
1 1/4"	120	106	65	250		63	40	F05	50	50	7	3.2
1 1/2"	130	113	72	250		63	40	F05	50	50	7	4.8
2"	150	131	90	315		40	40	F07	70	70	10	8.2
1/2" / R15	75	80	35	130	16			F04	42	42	5.8	0.6
3/4" / R15	80	80	35	130	16	100	63	F04	42	42	5.8	0.8
1" / R20	90	94	46	160	16	100	63	F04	42	42	5.8	1.4
1 1/4" / R25	110	98	50	160	16	63	40	F04	42	42	5.8	1.9
1 1/2" / R32	120	106	65	250	16	63	40	F05	50	50	7	2.8
2" / R40	140	113	72	250	16	63	40	F05	50	50	7	4.7